

POSITIVE DISPLACEMENT FLOWMETERS

M80 SERIES INSTRUCTION MANUAL

M80 Pulse; M80 Standard LCD. From Serial No.EXXXX



TO THE OWNER

Please take a few minutes to read through this manual before installing and operating your meter. Always retain this manual for future reference.

If you have any problems with the meter, refer to the maintenance and trouble shooting sections of this manual.

This manual contains connection and operating instructions for meters with Pulse outputs and Liquid Crystal Displays. Each model with a Liquid Crystal Display has an additional LCD instruction manual supplied.

If you need further assistance, contact your local representative or distributor for advice.

This Flow Meter has incorporated the oval rotor principal into its design. This has proven to be a reliable and highly accurate method of measuring flow.

Exceptional repeatability and high accuracy over a wide range of fluid viscosities and flow rates are features of the oval rotor design. The low pressure drop and high pressure rating means oval rotor flow meters are suitable for both gravity and pump (in line) applications.

Flow meters are available in either Aluminium or 316 Stainless Steel. Standard rotors are made from PPS (Polyphenylene Sulfide Resins) with optional 316 Stainless Steel rotors available for both Stainless steel and Aluminium models.

Meters are available with either:

- Pulse output
- LC Display and Pulse

IMPORTANT INFORMATION



PLEASE READ THIS INFORMATION CAREFULLY BEFORE USE!

Before use, confirm the fluid to be used is compatible with the meter. Refer to Industry fluid compatibility charts or consult your local representative for advice.

To prevent damage from dirt or foreign matter it is recommended that a Y or Basket type 60 mesh strainer be installed as close as possible to the inlet side of the meter. Contact your local representative for advice.

Note: When a strainer is installed it should be regularly inspected and cleaned. Failure to keep the strainer clean will dramatically effect flow meter performance.

Note: To prevent damage caused by air purge slowly fill the meter with fluid. To reduce pressure build up turn off the pump at the end of each day.

Maintenance can be carried out to the liquid crystal displays and pulse units without removing or isolating the meter from the line. When maintenance to any other part of the meter is required, the meter must be isolated and the line pressure reduced.

The reed switch pulse unit can cause inaccurate rate counts when used with high speed counters. It is advised that a debounce circuit be used. Contact your meter distributor for further information.

OPERATING PRINCIPLE

When fluid passes through the meter the rotors turn, as shown below. The magnets which are located in the rotors will pass across the pulser Circuit board (containing either Reed switches or Hall Effect sensors). A signal is generated which is then sent by the Pulse Circuit Board (PCB) to the relevant LC display or receiving instrument..

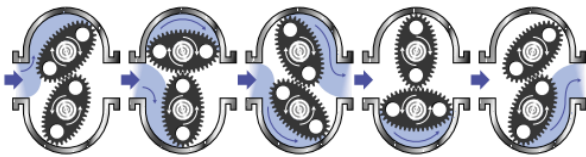

INSTALLATION

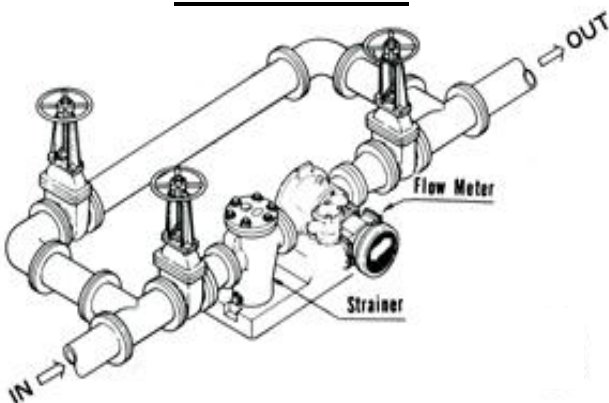

1) It is recommended that when setting up pipe work for meter installations a bypass line be included in the design. This provides the facility for a meter to be removed for maintenance without interrupting production. (See Fig.1)

2) Use thread sealant on all pipe threads.

3) For pump applications ensure pipe work has the appropriate working pressure rating to match the pressure output of the pump. See Meter Specifications section for further details.

4) Install a wire mesh strainer (Y or basket type 60 mesh as close as possible to the inlet side of the meter.

5) Ensure that the meter is installed so that the flow of the liquid is in the direction of the arrows embossed on the meter body.

6) The meter can be installed in any orientation as long as the meter shafts are in a horizontal plane. (Refer to Fig.2 for correct installation) The register assembly may be orientated to suit the individual.

Note: Incorrect installation can cause premature wear of meter components.

7) Do not over tighten meter connections.

Note: Incorrect installation can cause premature wear of meter components.

8) It is important that after initial installation you fill the line slowly, high speed air purge could cause damage to the rotors.

9) Test the system for leaks.

10) Check the strainer for swarf or foreign material, after the first 200 litres check periodically, particularly if the flow rate decreases.

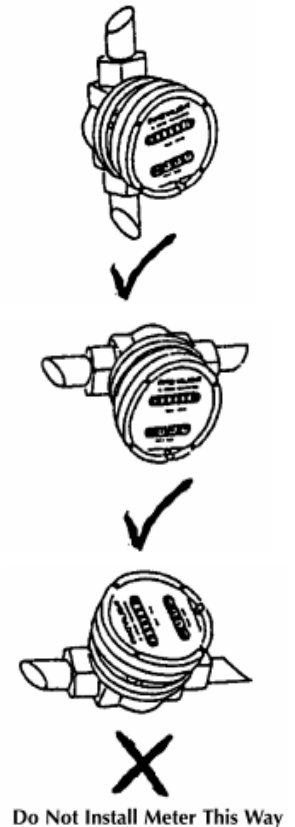

SERVICE INSTRUCTIONS

DISASSEMBLY

Ensure that the fluid supply to the meter is disconnected, and the line pressure is released before disassembly, with the exception for repair or maintenance to the LC Display or PCB where there is no necessity to isolate the meter from flow. Refer to the exploded parts diagram on subsequent pages for item numbers.

1a) Pulse Caps models: Undo the conduit connector, remove pulse cap (item 9) and remove the wires from the pulse terminal board (item 5).

1b) Standard LC Display: Mark the display orientation with a marking pen, unscrew the four large screws on top of the LC Display.

Carefully separate the LC Display from the plastic housing and disconnect the wires from the pulse terminal block. (Refer to additional LC Display instruction manual accompanying this instruction).

2) Remove the mounting adaptor plate and gasket.
Continued Over

3) Loosen the cap head screws (Item 7) that hold down the meter cap (Item 4), remove the screws, washers and lift off the cap.

4) Remove the o’ring (Item 2) from the o’ring groove in the meter cap (Item 4).

5) Remove rotors (Item 3).

REASSEMBLY

1) Before reassembling check the condition of the rotors (replace if necessary).

2) Check that the smooth side of the rotors (not the plug side) is facing you when inserting the rotors, the smooth side of the rotor is the magnet side. There is no difference between rotor one or rotor two.

3) Replace the rotors (Item 3) onto the shafts at 90 degrees to each other (refer Fig. 5) and check their operation by turning either of the rotors.

If the rotors are not in mesh correctly or do not move freely, remove one of the rotors and replace correctly at 90 degrees to the other rotor.

Re-check the operation of the rotors

4) Replace the o’ring (Item 2) into groove in the meter cap, if the o’ring has grown or is damaged in any way replace it with a new part.

5) Replace the meter cap making sure that the locating pin in the body lines up with the hole in the meter cap.

Insert the cap head screws (Item 7) and tighten in a diagonal sequence 1, 3, 2, 4, etc.

6) The replacement of cables and connectors are a reversal of the disassembly procedure, replace conduit fitting if required.

When replacing the Standard LC Display confirm the orientation marks made on disassembly are aligned then screw the register into place.

7) Test the meter by turning the rotors with a finger or by applying very low air pressure (no more than a good breath) to one end of the meter, before returning the meter to the line.

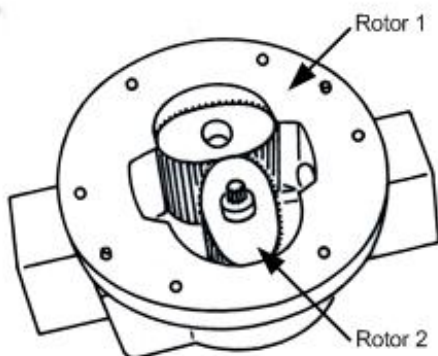

Rotors Must be 90° to each other

ELECTRICAL CONNECTIONS

Pulse Circuit Board (PCB) Notes:

The pulse PCB (Item 5) is fitted with (A) two reed switches; (B) hall effect sensors; or (C) one reed switch and one hall effect sensor.

The PCB board is fastened to the meter cap (Item 4) by two screws and stand off’s. All care and caution should be taken when removing or handling the PCB as both the reed switch and hall effect sensor are fragile.

Reed switch or hall effect sensors are not available as individual replacement parts and are only available with the complete PCB (Item 5).

Reed Switch Connections

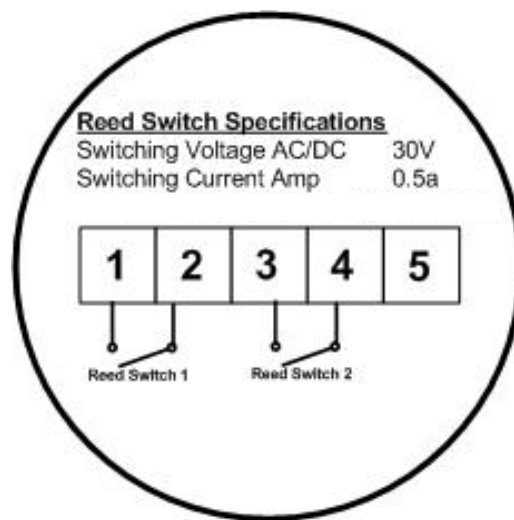

Hall Effect & Hall/Reed Switch Connections

<u>Configuration Reed / Hall Effect</u>		<u>Configuration Dual Hall Effect</u>	
Reed Switch	1 ○	HE Supply	+ 5 ~ 24vdc
Reed Switch	2 ○	HE 1 Signal Output	
HE Common 0V	3 ○	HE Common 0V	
HE Signal Output	4 ○	HE 2 Signal Output	
HE Supply + 5 ~ 24vdc	5 ○	linked to terminal 1	do not use

Notes: Hall Effect Sensor Current Draw: *Do not exceed 25mA*
 Output: NPN Open Collector ***no*** Resistor is provided on PCB
 With L C Displays, reed switch must be used.

Note: Consult following instructions if meter is fitted with LCD
 DR — DR013
 DRA — DR014
 ER — MS574
 ERA — MS476
 ERB — MS392
 ERS — MS351

ALUMINIUM METER PARTS LISTING

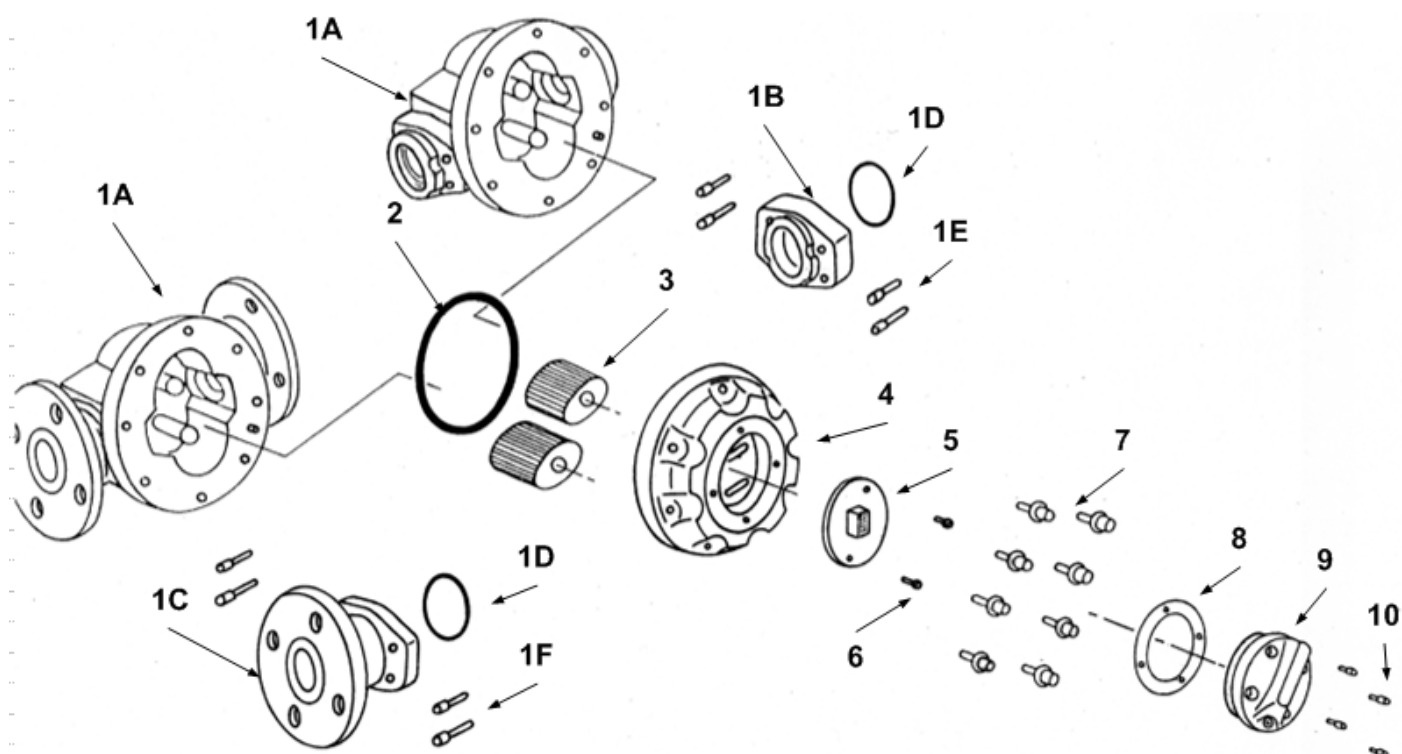

Item No.	No. Off	Rec. Parts	Part or Set (for order)	Part Description
1A	1		MS687S	Meter Body 1/2" Module (Aluminium)
1B	2		MS578S	3" BSP Flange (Aluminium)
1B	2		MS578NS	3" NPT Flange (Aluminium)
1C	2		MS579S	3" ANSI-150lb Flange (Aluminium)
1C	2		MS579DS	3" DIN-16 Flange (Aluminium)
1D	2	X	BS237ES	O-ring (EPDM)
1D	2	X	BS237TES	O-ring (FEP)
1D	2	X	BS237VS	O-ring (FKM)
1E	4		MS585S	Bolt set (To suit item 1B only)
1F	4		MS528s	Bolt set (To suit item 1C only)
2	1	X	BS262ES	O-ring (EPDM)
2	1	X	BS262TES	O-ring (FEP)
2	1	X	BS262VS	O-ring (FKM)
3	2		MS1198NS	Rotors (Aluminium)
3	2		MS1198HNS	High Viscosity Rotors (Aluminium)
4	1		MS588	Meter Cap (Aluminium)
5	1	X	MS430-RS	PCB (Standard Reed Switch)
5	1	X	MS430-HES	PCB (Hall Effect Sensor)
5	1	X	MS430-R/HES	PCB (1 Reed Switch & 1 Hall Effect Switch)
6	2		MS284S	PCB Board Screws
7	8		MS243S	Meter Cap Screws (Standard)
8	1		MS300S	Pulser Cap Gasket
9	1		MS160	Pulser Cap (Aluminium) 20mm Conduit Thread
9	1		MS160N	Pulser Cap (Aluminium) 1/2" NPT Thread
10	2		MS115S	Pulser Cap Screw (Stainless Steel)

STAINLESS STEEL METER PARTS LISTING

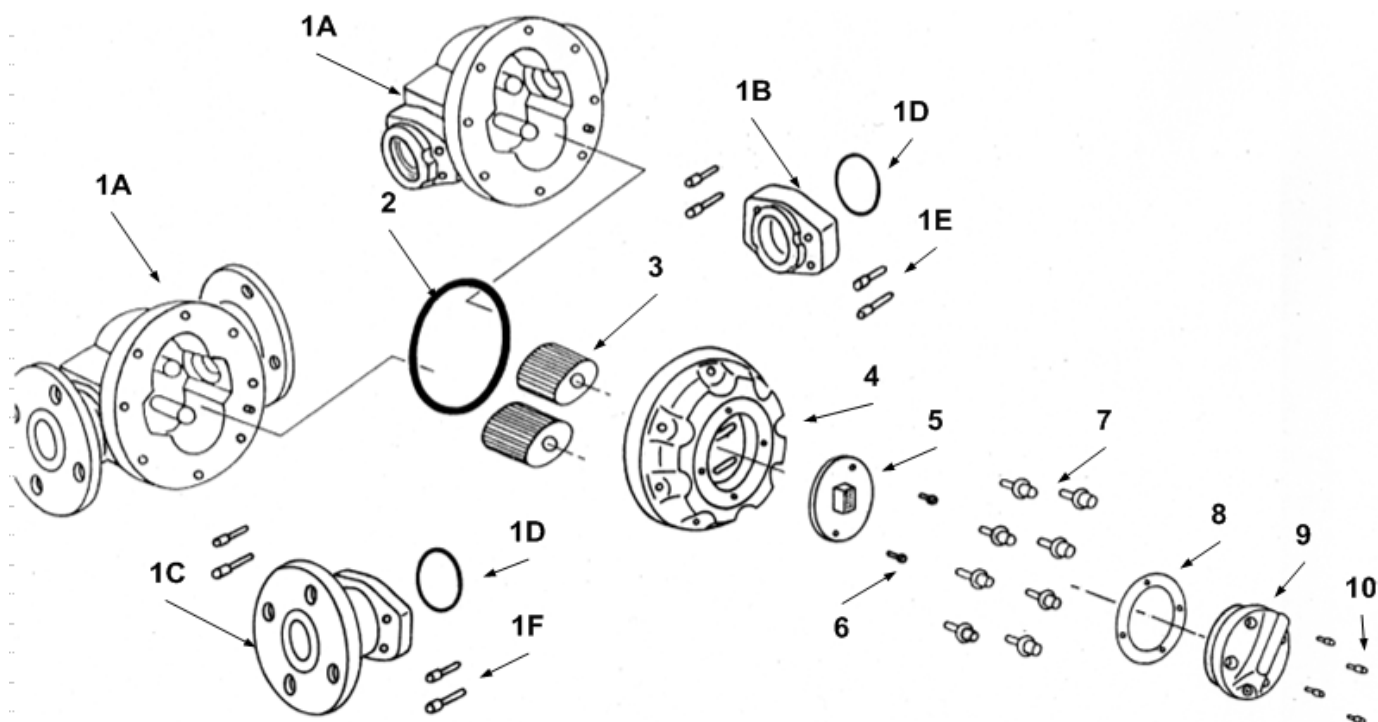

Item No.	No. Off	Rec. Parts	Part or Set (Order from this column only)	Part Description
1A	1		MS687S	Meter Body Module (Stainless Steel)
1B	2		MS723S	3" BSP Flange (Stainless Steel)
1B	2		MS723NS	3" NPT Flange (Stainless Steel)
1C	2		MS749S	3" ANSI - 150lb Flange (Stainless Steel)
1C	2		MS749DS	3" DIN-16 Flange (Stainless Steel)
1D	2	u	BS237ES	O-Ring (EPDM)
1D	2	u	BS237TES	O-Ring (FEP)
1D	2	u	BS237VS	O-Ring (FKM)
1E	4	u	MS431S	Bolt Set (To suit item 1B only)
1F	4	u	MS272S	Bolt Set (To suit item 1C only)
2	1	u	BS262ES	O-Ring (EPDM)
2	1	u	BS262TES	O-Ring (FEP)
2	1	u	BS262VS	O-Ring (FKM)
3	2	u	MS1178RS	Rotors (Stainless Steel) Reed Switch
3	2	u	MS1178ES	Rotors (Stainless Steel) Hall Effect Switch
3	2		MS1178RKS	High Viscosity Rotors (Stainless Steel) Reed Switch
4	1	u	MS748	Meter Cap (Stainless Steel)
5	1	u	MS430-RS	PCB (Standard Reed Switch)
5	1		MS430-HES	PCB (Hall Effect Sensor)
5	2		MS430-R/HES	PCB (1 Reed Switch and 1 Hall Effect Sensor)
5	8	u	MS284S	PCB Board Screws
6	1	u	MS282S	Meter Cap Screws (Stainless Steel)
7	1		MS300S	Pulser Cap Gasket
8	1		MS170S	Pulser Cap (Stainless Steel) 20mm Conduit Thread
9	2		MS170NS	Pulser Cap (Stainless Steel) 1/2 NPT Thread
9			MS115S	Pulser Cap Screw (Stainless Steel)
10				

METER SPECIFICATIONS

Meter Type	Pulse
Flow Range (Litre/min. or Gal. / min) Above 5 centipoise	20 to 733 / 5 to 194
Accuracy of reading	+/- 0.5%
Maximum Viscosity*	1000 centipoise
Max. Operating Pressure	1200kPa/175PSI/12 BAR
Max. Operating Temperature	80C/176F
Pulse Type	Hall or Reed Switch
Pulses per Litre/US Gallon	2.58/9.76

METER TROUBLE SHOOTING

TROUBLE	CAUSE	REMEDY
Fluid will not flow through meter	a) Foreign matter blocking rotors b) Line strainer blocked c) Damaged rotors d) Meter connections over tightened e) Fluid is too viscous	a) Dismantle meter, clean rotors (strainer must be fitted in line) b) Clean strainer c) Replace rotors (Strainer must be fitted in line) d) Re-adjust connections e) See specifications for maximum viscosity
Reduced flow through meter	a) Strainer is partially blocked b) Fluid is too viscous	a) Clean strainer b) See specifications for maximum viscosity
Meter reading inaccurate	a) Fluid flow rate is too high or too low b) Fluid is too viscous c) Excess wear caused by incorrect installation	a) See specifications for minimum and maximum flow rates b) Bleed air from system c) Check meter body and rotors. Replace as required. Refer to installation instructions
Meter not giving a pulse signal	a) Faulty hall effect sensor b) Faulty reed switch c) Magnets failed	a) Replace PCB Board b) Replace PCB Board c) Replace magnets
LCD register not working	a) Battery not connected properly b) Battery flat c) Faulty wiring connections d) Faulty LC Display e) Faulty connection from LC Display	a) Check battery connections b) Replace battery c) Check wiring for loose or faulty connections d) Replace LC Display e) Check wiring connections

Dimensions

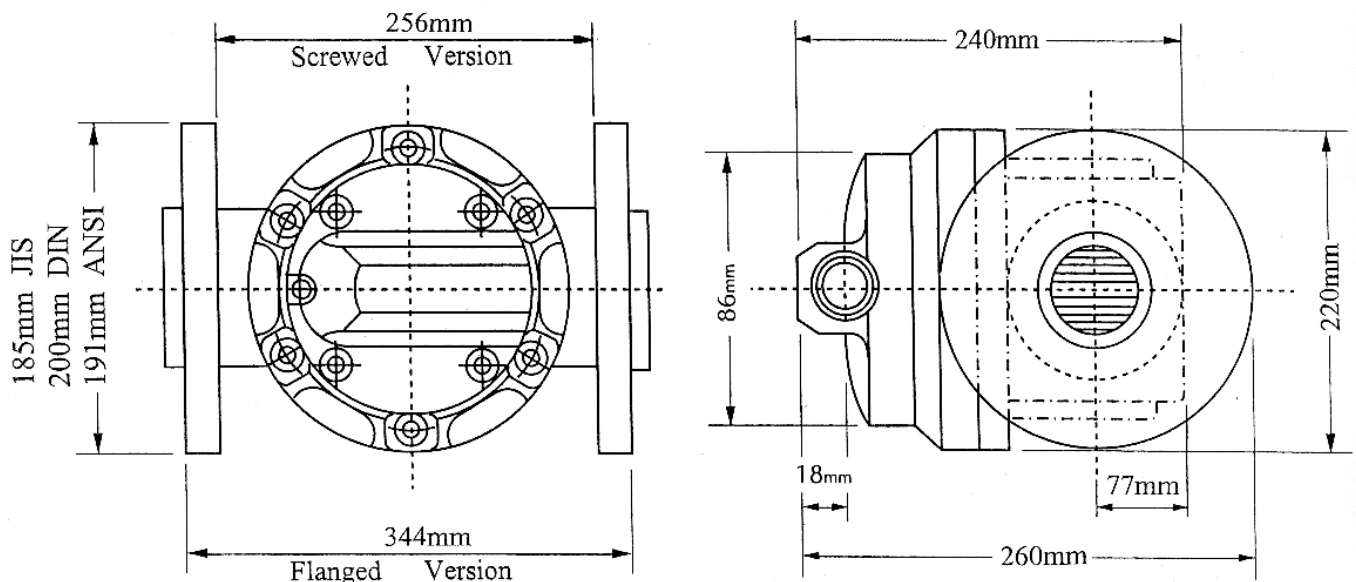

macnaught warranty

1. Macnaught Pty Ltd (“Macnaught”) warrants that all products manufactured by Macnaught and/or supplied by Macnaught under the “Macnaught” brand, excluding M-SERIES, MEC-SERIES and WM-SERIES positive displacement meters (“Meters”) and components subject to wear, will be free from any defects caused by faulty materials or workmanship (“Warranty”) for a period of 5 years from the date of purchase of the product.
2. For products (excluding Meters) which carry the “Macnaught design” endorsement, an additional Warranty period of 5 years applies to all mechanical components (excluding electronic and electrical components), giving a total Warranty period of 10 years.
3. For Meters, the Warranty period is 2 years from the date of purchase of that product.
4. For components contained in all products which are usually subject to wear from normal operation of the products (such as o-rings, seals, bushes, springs, hoses and batteries), the Warranty period is 12 months from the date of purchase of the relevant product.
5. For products and components which are not manufactured by Macnaught and are supplied by Macnaught under a brand name other than “Macnaught”, the Warranty period is the longer of 12 months from the date of purchase of the relevant product and the period of the manufacturer’s warranty.
6. The warranties contained in clauses 1, 2, 3, 4 and 5 above are conditional on the purchaser, during the relevant Warranty period:
 - A. delivering to Macnaught a detailed notice setting out full details of any defect in any product and details of the date and place of purchase (together with copies of purchase receipts and/or other supporting documents); and
 - B. at the purchaser’s own cost, returning the defective product to the nearest authorised Macnaught service centre.
7. Subject to compliance by the purchaser with clause 6, Macnaught shall, at its option, repair or replace any product or component found defective by its inspection by reason of faulty materials or workmanship of Macnaught.
8. This Warranty does not cover the failure of products, parts or components which, in the sole judgment of Macnaught, arises other than from faulty materials or workmanship of Macnaught, including misuse, abrasion, corrosion, negligence, accident, substitution of non-Macnaught parts, unauthorised modification, improper use, storage or handling, faulty installation or tampering by the purchaser or any third party.
9. If Macnaught’s inspection discloses no defect in material or workmanship, repair or replacement and return (at Macnaught’s sole option) will be made at customary charges, which will be advised to the purchaser.
10. Macnaught’s liability and the purchaser’s rights under this Warranty shall be limited to the repair or replacement of defective products or components and in particular, shall not extend to any direct, special, indirect or consequential damage or losses of any nature.
11. The foregoing Warranty supersedes, voids and is in lieu of all or any other warranties.

This Warranty does not form part of, nor does it constitute, a contract between Macnaught and the end-user or purchaser. It is additional to any warranty given by the seller of the products. This Warranty does not exclude, limit, restrict or modify the non-excludable rights or remedies conferred upon the end-user or purchaser, or the non-excludable duties or liabilities imposed on the seller or Macnaught, by Part V, Divisions 2, 2A and Part VA of the Trade Practices Act 1974 (Commonwealth) or other legislative provisions. Macnaught otherwise excludes, to the extent permitted by law, any rights conferred on the end-user or purchaser or duties or liabilities imposed upon Macnaught.



Macnaught Pty Ltd
PO Box 90 Arncliffe NSW 2205 Australia
Telephone (02) 9567 0401
Facsimile (02) 9597 7773
Email: sales@macnaught.com.au
Web: www.macnaught.com.au