

IM155
0107
0005



IM75 (ELECTRONIC) POSITIVE DISPLACEMENT FLOWMETERS INSTRUCTION MANUAL

INTRODUCTION

Thank you for purchasing a Macnaught Positive Displacement Flowmeter.

The Macnaught IM75 Positive displacement flowmeter have incorporated the oval rotor principal into its design. This has proven to be a highly reliable and highly accurate method of measuring flow, providing exceptional repeatability and high accuracy.

The IM75 meter can be connected to a Macnaught oil dispensing nozzle or can be installed and used as an in line meter.

Macnaught manufacture a full range of pumps and accessories to suit most of your fluid transfer needs, please consult your local Macnaught reseller for more information.

With appropriate care combined with the Macnaught Guarantee of dependable after sales service, (provided by our worldwide distribution network), you will be assured of continuous safe, efficient and reliable product operation.

Please read and retain this instruction manual to assist you in the operation and maintenance of this quality product.

GENERAL INFORMATION

This manual assists you in operating and maintaining your new positive displacement flowmeter. The information contained will help you ensure many years of dependable performance and trouble free operation.

Please take a few moments to read through this manual before installing and operating your new meter. If you experience problems with this product, refer to the Maintenance and Trouble Shooting sections of this manual. If you require further assistance please contact your local Macnaught Distributor, Authorised Macnaught Service Centre or Macnaught P/L.



IMPORTANT INFORMATION

Macnaught recommends, that if you are using your meter as an in-line application you should install a filter before the inlet of the meter. Contact your local Macnaught distributor for further details.



INSTALLATION

- 1) Do not over tighten connections.

OPERATION

IM75 ELECTRONIC REGISTER

DISPLAY BUTTON

Each press of the **DISP** button will allow you to scroll through the meter options

- Resetable Batch Total
- Resetable Accumulative Total
- Non Resetable Accumulative Total
- Flowrate

RESET BUTTON

The **RESET** button allows you to reset the Batch Total or the Resettable Accumulative Total to zero.

To reset either the Batch total or Resettable Accumulative total. Press the **DISP** button to scroll to either the Batch or Resettable total. When the required total is displayed. Press **RESET** to zero the totalizer.

FLOWRATE

This display option shows the flowrate of the fluid passing through the meter.

SLEEP MODE

If **NO** flow goes through the meter for 60 seconds the display will go into sleep mode (Blank). The display will automatically wake if the buttons are pressed or flow occurs.

BATTERY REPLACEMENT

All data will be saved when the batteries are removed.

Note: Replace the batteries as soon as the battery indicator on the LCD is displayed



- 1) Remove the plastic protector shroud from the meter body. (fig 1)
- 2) Remove the battery cover.
- 3) Replace the 2 x (AAA) Alkaline batteries. (Refer to the front of the meter for correct battery orientation).
- 4) Replace the battery cover and re-fit the plastic shroud.

Note: Only use Alkaline batteries.

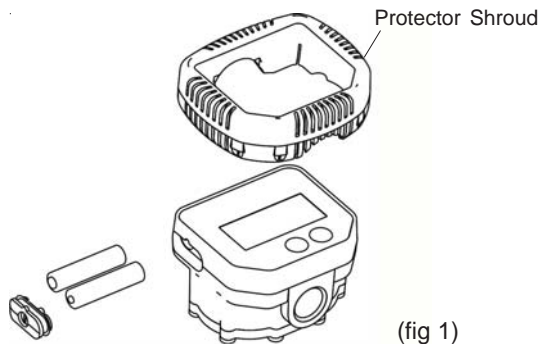

(fig 1)



CAUTION

Ensure the fluid supply to the meter is disconnected and the line pressure is released before disassembly.

METER DISASSEMBLY

Note: The electronic computer module is non-repairable. The meter will need to be replaced if found to be damaged or faulty.

- 1) Remove the 8 x socket head screws (1) from the meter cover.
- 2) Remove the meter cover (2) and o'ring (3).
- 3) Remove both rotors (4).
- 4) Clean and inspect all parts. Replace any suspect, worn or damaged components.

METER REASSEMBLY

NOTE: Ensure the rotor with the magnets is assembled on the same side to the batteries. The magnets in the rotor must face towards the electronic display .

- 1) Replace both rotors (4) so as they are at 90° to each other. (see fig 2). Check the rotor rotation by turning either of the rotors. If the rotors are not in mesh correctly or do not rotate freely remove one of the rotors and replace it correctly at 90° to the other rotor. Re-check the operation of the rotors.
- 2) Lightly grease the o'ring (3) and place it on the meter body.
- 3) Clean the meter cover plate (2) and place it on the body. Take care not to damage the o'ring (3).

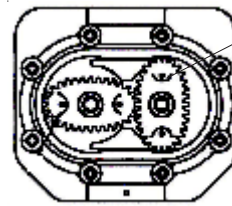

The Rotor with Magnets

(fig 2)

- 4) Install the 8 screws (1) and tighten in a diagonal pattern to 2nm (1.5 ft.lb). Visual check the cap has been pulled down evenly.
- 5) Test the meter by turning the rotors with a finger or by applying low air pressure (No more than a good breath) to the inlet port of the meter. This will confirm the meter is operating correctly.

PARTS DIAGRAM

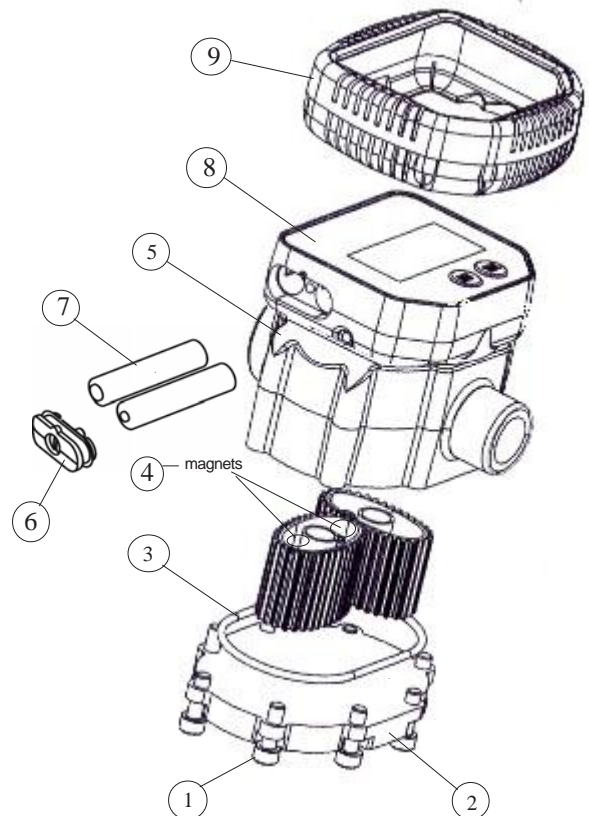

PARTS LIST

ORDER FOR REPLACEMENT				DESCRIPTION
ITEM	PART NO	No. off	PART/SET	
1	MS277	8	IM152s	SCREWS
2	IM152	1		METER COVER PLATE
3	BS147	1	ME022s	O'RING SEAL
4	ME022	2		ROTOR SET
5		1	N/A	METER BODY
6	IM060A	1	IM060As	BATTERY COVER
7	IM066	2	IM066s	BATTERIES
8		1	N/A	ELECTRONIC MODULE
9	IM071	1	IM071BKS = (BLACK)	PROTECTIVE SHROUD
9	IM071	1	IM071BUS = (BLUE)	PROTECTIVE SHROUD
9	IM071	1	IM071GRS = (GREEN)	PROTECTIVE SHROUD
9	IM071	1	IM071RDS = (RED)	PROTECTIVE SHROUD
9	IM071	1	IM071YLS = (YELLOW)	PROTECTIVE SHROUD

ELECTRONIC MODULE

PROGRAMING DETAILS

The electronic module has been set up as follows:-

- a) Ensure the meter is awake before trying to enter the programming mode.
- b) If the meter goes into sleep mode during programming, it will automatically return to operating mode.
- c) To access the programs and settings, hold down the **RESET** button for 5 seconds



- d) To scroll through the setting options press the **DISP** button.

NOTE: Details for changing individual options .

For example to change the units setting on the batch total turn to item 2 - 21

2. TOTALS



totL 2

- 21 change batch total (units)
- 22 change batch total (decimal point)
- 23 change resetable accumulative total (units)
- 24 change resetable accumulative total (decimal point)
- 25 change non-resetable accumulative total (units)
- 26 change non-reset accumulative total (decimal point)
- 27 change "K" factor

3. FLOWRATE



rAtE 3

- 31 change flowrate (units)
- 32 change flowrate (decimal point)
- 33 change flowrate (time base setting)
- 34 set the amount of signal pulses to calculate flowrate
- 35 set minimum flow rate

4. DISPLAY



diSP 4

- 41 set sleep mode
- 42 change display (wake up default setting)
- 43 set sleep time

5. CALIBRATION



CALi 5

- 51 calibration adjustment

6. CONFIGURATION



CONF 6

- 6 configuration details

7. DIAGNOSTICS



dIA 7

- 71 diagnostic mode

2. TOTALS SETTINGS

totL2

21 BATCH TOTAL = unit 21 (set units)

- Press and hold down **RESET** for 5 seconds until "totL2" appears.
- Press **RESET** " unit 21" will appear.
- Press and hold down **RESET** for 2 seconds (program will appear)
- Press **RESET** to scroll through the settings (ltr, gal, qrt) to the desired units
- Press and hold down **RESET** until "program" disappears to accept setting.
- Press "**RESET**" for five seconds to return the meter to the operating mode.

22 BATCH TOTAL = dEC 22 (set decimal point)

- Press and hold down **RESET** for 5 seconds until "totL2" appears.
- Press **RESET** twice " dEC 22" will appear.
- Press and hold down **RESET** for 2 seconds (program will appear)
- Press **RESET** to set the decimal point to 1st, 2nd, 3rd or no decimal place. (e.g 11111.1 = 1 decimal place)
- Press and hold down **RESET** until "program" disappears to accept setting.
- Press **RESET** for five seconds to return the meter to the operating mode.

23 RESETABLE ACCUM TOTAL = unit 23 (set units)

- Press and hold down **RESET** for 5 seconds until "totL2" appears.
- Press **RESET** 3 times " unit 23" will appear.
- Press and hold down **RESET** for 2 seconds (program will appear)
- Press **RESET** to scroll through the settings (ltr, gal, qrt) to the desired units
- Press and hold down **RESET** until "program" disappears to accept setting.
- Press **RESET** for five seconds to return the meter to the operating mode.

24 RESETABLE ACCUM TOTAL = dEC 24 (set decimal point)

- Press and hold down **RESET** for 5 seconds until "totL2" appears.
- Press **RESET** 4 times " dEC 24" will appear.
- Press and hold down **RESET** for 2 seconds (program will appear)
- Press **RESET** to set the decimal point to 1st, 2nd, 3rd or no decimal place (e.g. 11111.1 = 1 decimal place).
- Press and hold down **RESET** until "program" disappears to accept setting.

- Press **RESET** for five seconds to return the meter to the operating mode.

25 NON-RESET ACCUM TOTAL = unit 25 (set units)

- Press and hold down **RESET** for 5 seconds until "totL2" appears.
- Press **RESET** 5 times " unit 25" will appear.
- Press and hold down **RESET** for 2 seconds (program will appear)
- Press **RESET** to scroll through the settings (ltr, gal, qrt) to the desired units.
- Press and hold down **RESET** until "program" disappears to accept setting.
- Press **RESET** for five seconds to return the meter to the operating mode.

26 NON-RESET ACCUM TOTAL = dEC 26 (set decimal point)

- Press and hold down **RESET** for 5 seconds until "totL2" appears.
- Press **RESET** 6 times " dEC 26" will appear.
- Press and hold down **RESET** for 2 seconds (program will appear)
- Press **RESET** to set the decimal point to 1st, 2nd, 3rd or no decimal place (e.g. 11111.1 = 1 decimal place).
- Press and hold down **RESET** until "program" disappears to accept setting.
- Press **RESET** for five seconds to return the meter to the operating mode.

27 "K" FACTOR = kFac 27 (normal setting is 112.00 pulses)

- Press and hold down **RESET** for 5 seconds until "totL2" appears.
- Press **RESET** 7 times " kFac 27" will appear.
- Press and hold down **RESET** for 2 seconds (program will appear)
- To change the 'K' factor, press **RESET** (digit will flash), to change digit press **RESET**.

Press **DISP** to scroll to the next number. Press **RESET** to change the value

To change the decimal point, press **DISP** until it is in the required position. Press **RESET** to set the decimal point.

- Press and hold down **RESET** until "program" disappears to accept setting.
- Press **RESET** for five seconds to return the meter to the operating mode.

3. FLOW RATE

rAtE 3

31 UNITS = unit 31 (set units)

- Press and hold down **RESET** for 5 seconds until "totL2" appears.
- Press the **DISP** button 1 time to reach "rAtE 3"

- c) Press **RESET** “ unit 31” will appear.
- d) Press and hold down **RESET** for 2 seconds (program will appear)
- e) Press **RESET** to scroll through the settings (ltr, gal, qrt) to the desired units
- f) Press and hold down **RESET** until “program” disappears to accept setting.
- g) Press **RESET** for five seconds to return the meter to the operating mode.

32 DECIMAL POINT = dEC 32. (decimal point setting)

- a) Press and hold down **RESET** for 5 seconds until “totL2” appears.
- b) Press the **DISP** button 1 time to reach “rAtE 3”
- c) Press **RESET** twice “ dEC 32” will appear.
- d) Press and hold down **RESET** for 2 seconds (program will appear)
- e) Press **RESET** to set the decimal point to 1st, 2nd, 3rd or no decimal place (e.g. 11111.1 = 1 decimal place)
- f) Press and hold down **RESET** until “program” disappears to accept setting.
- g) Press **RESET** for five seconds to return the meter to the operating mode.

33 TIME = tiME 33 (rate time base)

- a) Press and hold down **RESET** for 5 seconds until “totL2” appears.
- b) Press the **DISP** button 1 time to reach “rAtE 3”
- c) Press **RESET** 3 times “tiME 33” will appear.
- d) Press and hold down **RESET** for 2 seconds (program will appear)
- e) Press **RESET** to set time base (seconds, minutes, hours)
- f) Press and hold down **RESET** until “program” disappears to accept setting.
- g) Press **RESET** for five seconds to return the meter to the operating mode.

34 NUMBER OF PULSES = nuM 34 (Number of pulses used to calculate flowrate)

Note: When there is fluctuating flowrate present increasing the number will give a more accurate flowrate reading. (number range is 0 - 299)

- a) Press and hold down **RESET** for 5 seconds until “totL2” appears.
- b) Press the **DISP** button 1 time to reach “rAtE 3”
- c) Press **RESET** 4 times “ NUM 34” will appear.
- d) Press and hold down **RESET** for 2 seconds (program will appear and the digit will flash). To change press **RESET**
- e) Press **DISP** to go to the next digit. To change press **RESET**
- f) Press and hold down **RESET** until “program” disappears to accept setting.

- g) Press **RESET** for five seconds to return the meter to the operating mode

35 FLOW = Cut 35 (Set minimum measurable flowrate)

This value is the maximum time (sec) to measure the number of pulses set in nuM34

- a) Press and hold down **RESET** for 5 seconds until “totL2” appears.
- b) Press the **DISP** button 1 time to reach “rAtE 3”
- c) Press **RESET** 5 times “ Cut 35” will appear.
- d) Press and hold down **RESET** for 2 seconds (program will appear and the digit will flash). To change press **RESET**
- e) Press **DISP** to go to the next digit. To change press **RESET**

Note : Total number 999.9

- f) Press and hold down **RESET** until “program” disappears to accept setting.
- g) Press **RESET** for five seconds to return the meter to the operating mode.

4. DISPLAY diSP 4

- a) Press and hold down **RESET** for 5 seconds until “totL2” appears.
- b) Press the **DISP** button 2 times to reach “diSP 4”
- c) Press **RESET** “ SLP41” will appear.
- d) Press and hold down **RESET** for 2 seconds (program will appear)
- e) Press **RESET** to select sleep setting (no sleep, sleep)
- f) Press and hold down **RESET** until “program” disappears to accept setting.
- g) Press **RESET** for five seconds to return the meter to the operating mode.

42 UNIT = unit 42 (set default display)

Note: The display will reset to the default units after a time which is set in time 43. If no units are set, the display will remain as selected

- a) Press and hold down **RESET** for 5 seconds until “totL2” appears.
- b) Press **RESET** 2 times “ unit 42 ” will appear.
- c) Press and hold down **RESET** for 2 seconds (program will appear)
- d) Press **RESET** to select required display (batch, reset total, total, rate, blank)
- e) Press and hold down **RESET** until “program” disappears to accept setting.
- f) Press **RESET** for five seconds to return the meter to the operating mode.

43 TIME = tiME 43 (time to revert to default display)

- a) Press and hold down **RESET** for 5 seconds until “totL2” appears.
- b) Press the **DISP** button 2 times to reach “tiME 43”.
- c) Press and hold down **RESET** for 2 seconds (program will appear).

- d) Press **RESET** to select default time (5-20 seconds).
- e) Press and hold down **RESET** until “program” disappears to accept setting.
- f) Press **RESET** for five seconds to return the meter to the operating mode.

5. CALIBRATION CALI 5

Note: Provides calibration adjustment up to +/- 5% of reading. You will need to calculate the percentage adjustment you require. If the meter is reading over you will need to enter a minus figure. If the meter is reading under you will need to enter a plus figure.

Step 1. Reset the batch reading to zero.

Step 2. Dispense at least 5 liters, using a constant flow rate, into a graduated calibrated container.

Step 3. Take the reading from the IM50.

Step 4. Calculate the % error as follows.

$$\% \text{ error} = ((\text{container volume} - \text{IM50 volume}) / \text{container volume}) * 100$$

Step 5. Enter the % error into the meter as calculated, if the value is negative enter a negative number

51 CALIBRATION = CALI 51 (adjust calibration +/- 5%)

- a) Press and hold down **RESET** for 5 seconds until “totL2” appears.
- b) Press the **DISP** button 3 times to reach “CALI 5”
- c) Press **RESET** “CALI 51” will appear.
- d) Press and hold down **RESET** for 2 seconds (program will appear and the first digit will flash)
- e) Press **RESET** to change number.
Press **DISP** to change the decimal point position, or go to the next number.
Press the **RESET** button to set the negative value.
- f) Press and hold down **RESET** until “program” disappears to accept setting.
- g) Press **RESET** for five seconds to return the meter to the operating mode.

6. CONFIGURATION CONF 6

6 CONFIGURATION = CONF 6 (configuration details)

- a) Press and hold down **RESET** for 5 seconds until “totL2” appears.
- b) Press the **DISP** button 4 times to reach “CONF 6”
- c) Press **RESET** “MOD” plus model number will appear.
- d) Press **RESET** “REL” plus hardware release number will appear.
- e) Press **RESET** the screen will flash between “SOFT” and the software release no’s (at 2 second intervals)
- f) Press **RESET** the screen will flash between “SE” and the 6 figure serial number (at 2 second intervals)
- g) Press **RESET** “MAN” plus manufacturer number

- h) Press **RESET** the screen will flash between “CONFIG” and the configuration number (at 2 second intervals).
- i) Press **RESET** for five seconds to return the meter to the operating mode.

7. DIAGNOSTICS dIA 7

71 DIAGNOSTICS = dIA 7 (diagnostic mode)

- a) Press and hold down **RESET** for 5 seconds until “MEtr 1” appears.
- b) Press the **DISP** button 5 times to reach “dIA 7”
- c) Press **RESET** “ dIA 71” will appear.
- d) Press and hold down **RESET** for 2 seconds (Program will appear then all the segments should be displayed).
- e) Press the **DISP** button “diSP” (to check that the display button is working properly).
- f) Press the **RESET** button “RESEt” (to check that the reset button is working properly).
- g) Press and hold down **RESET** for 2 seconds (Program will disappear (check the condition of the reed switch).

Note: The display shows (Hxx rYY) when fluid flows through the meter. YY is the sensitivity of the reed switch.

The condition of the reed switch can only be checked when there is liquid flowing through the meter. The reed switch should be reading between 50 - 80.

- h) Press **RESET** for five seconds to return the meter to the operating mode.

NOTES:

TROUBLE SHOOTING GUIDE

TROUBLE	CAUSE	REMEDY
No fluid passing through the meter	a) Dirt particles jamming the rotors	a) Remove rotors and remove any dirt or contamination
The meter is not registering fluid output	a) Flat battery	a) Replace battery
	b) No signal from rotor the magnets	b) Check magnets and replace rotors if required
	c) Damaged computer (reed switch unit)	c) Replace meter
Meter not accurate	a) Flowrate outside recommended flow rate	a) Adjust flowrate to
	b) "K" factor incorrect	b) Re-set "K" factor to factory setting (52 pulses)

SPECIFICATIONS

Accuracy	+ / - 0.5% of Reading
Type	Oval Gear
Flow rate	3 Ltr -80 Ltr (0.8 - 21.1 US Gal) per minute
Maximum Working Pressure	10350kPa / 1500psi / 103.5 Bar
Suitable for use with :	Engine Oil, Diesel Oil, Automatic Transmission Fluid (Maximum Viscosity SAE140), Ethelene Glycol Based Anti-Freeze / Anti-Boil mixture (Max 50% water)
Wetted Materials	Acetal, Aluminium, Steel, Nitrile Rubber
Battery Type	2 x AAA Alkaline
Resettable Totalizer	999999 (ltr or gal)
Non-Resettable Totalizer	999999 (ltr or gal)
Connections	3/4" NPT (Female) or 3/4" BSP.PL (Female)
Maximum Temperature	55 deg C (131 deg F)
Minimum Temperature	-5 deg C (23 deg F)

macnaught
 Macnaught Pty Ltd
 PO Box 90 Arncliffe NSW 2205 Australia
 Telephone (02) 9567 0401
 Facsimile (02) 9597 7773
 Email: sales@macnaught.com.au
 Web: www.macnaught.com.au



macnaught warranty

- Macnaught Pty Ltd ("Macnaught") warrants that all products manufactured by Macnaught and/or supplied by Macnaught under the "Macnaught" brand, excluding M-Series positive displacement meters ("Meters") and components subject to wear, will be free from any defects caused by faulty materials or workmanship ("Warranty") for a period of 5 years from the date of purchase of the product.
- For products (excluding Meters) which carry the "Macnaughtdesign" endorsement, an additional Warranty period of 5 years applies to all mechanical components (excluding electronic and electrical components), giving a total Warranty period of 10 years.
- For Meters, the Warranty period is 12 months from the date of purchase of the product.
- For components contained in all products which are usually subject to wear from normal operation of the products (such as o-rings, seals, springs, hoses and batteries), the Warranty period is 12 months from the date of purchase of the relevant product.
- For products and components which are not manufactured by Macnaught and are supplied by Macnaught under a brand name other than "Macnaught", the Warranty period is the longer of 12 months from the date of purchase of the relevant product and the period of the manufacturer's warranty.
- The warranties contained in clauses 1, 2, 3, 4 and 5 above are conditional on the purchaser, during the relevant Warranty period:
 - delivering to Macnaught a detailed notice setting out full details of any defect in any product and details of the date and place of purchase (together with copies of purchase receipts and/or other supporting documents), and
 - at the purchaser's own cost, returning the defective product to the nearest authorised Macnaught service centre.
- Subject to compliance by the purchaser with clause 6, Macnaught shall, at its option, repair or replace any product or component found defective by its inspection by reason of faulty materials or workmanship of Macnaught.
- This Warranty does not cover the failure of products, parts or components which, in the sole judgment of the Macnaught, arises other than from faulty materials or workmanship of Macnaught, including misuse, abrasion, corrosion, negligence, accident, substitution of non-Macnaught parts, unauthorised modification, improper use, storage or handling, faulty installation or tampering by the purchaser or any third party.
- If Macnaught's inspection discloses no defect in material or workmanship, repair or replacement and return (at Macnaught's sole option) will be made at customary charges, which will be advised to the purchaser.
- Macnaught's liability and the purchaser's rights under this Warranty shall be limited to the repair or replacement of defective products or components and particular, shall not extend to any direct, special, indirect or consequential damage or losses of any other warranties.
- The foregoing Warranty supersedes, voids and is in lieu of any other warranties. This Warranty does not form part of, nor does it constitute, a contract between Macnaught and the end-user or purchaser. It is additional to any warranty given by the seller of the products. This Warranty does not exclude, limit, restrict or modify the non-excludable rights or remedies conferred upon the end-user or purchaser, or the non-excludable duties or liabilities imposed on the seller or Macnaught, by Part V, Division 2, 2A, and Part VA of the Trade Act 1974 (Commonwealth) or other rights conferred on the end-user or purchaser or duties or liabilities imposed upon Macnaught.